



ABOVE AND BEYOND HONING

SV-20

VERTICAL HONING MACHINE



SV-20 UNC-2B
400 MAX FULL THREAD
3" DIA DRILL
3" DIA 90° X 90°
SUNNEN (M)

2" X 1/2" MIN
3000 RPM

SV-20 UNC-2B
400 MAX FULL THREAD
3" DIA DRILL
3" DIA 90° X 90°
SUNNEN (M)

E

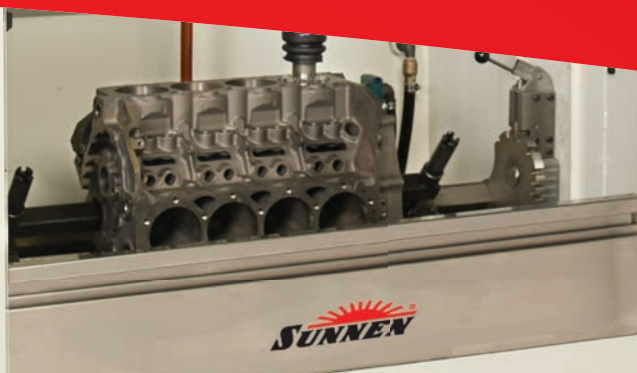

The SV-20 is the latest industry-leading Sunnen vertical honing system. It is built to make your vertical honing faster, easier, more precise, more productive and more profitable.

- Designed for bores with an ID of 19 - 200 mm (0.75 - 8 inches).
- PLC controlled with a large color touch screen for ease of use and setup .
- Built to handle large parts including diesel engine blocks.
- Vertical stroking mechanism improves geometry over previous generation, similarly priced machines.
- Built and backed by Sunnen – the leader in honing since 1924.

Your Sunnen Technical Specialist will work with you to determine the best solution for your needs – it's all part of the added value you get with Sunnen. Plus, our worldwide sales and service team provides comprehensive support for the installation and operation of every system we make.

Whatever your need, we have the expertise and product range to create the right solution for you and the dedication to support you for the long run.

*To find the Sunnen representative nearest you, visit our website:
www.sunnen.com*



THE SV-20 DRIVES DIAMOND ABRASIVES IN THE PRODUCTION OR JOB SHOP.

STANDARD & OPTIONAL FEATURES

- 1 Variable speed 15-600 rpm, 4.1 kW (5.5 HP) spindle motor is powerful enough to drive two-stage, metal-bond, diamond abrasives for short cycle times with high accuracy and minimal labor and has more torque than previous machines.
- 2 The front loading design and weight capacity of up to 600 kg (1325 lbs) combine for versatility in honing a wide range of parts.
- 3 PLC-controlled with a large 203.2 mm (8 in) color touch screen that is rugged and eliminates cumbersome buttons that collect oil, dirt and grime. The swiveling operator panel can be adjusted for viewing from a variety of positions.
- 4 Hand wheel allows left/right positioning of the column with 838 mm (33 in) range
- 5 Servo rotary tool feed system can be used with two-stage hone heads to complete roughing and finishing without stone changes for faster processing times. Rough to finish changeover is four times faster than previous models.

Standard 284 liter (75 gallon) internal coolant system is equipped with two standard canister filters on the back of the machine, saving valuable floor space.

- 6 Proven 2.5 kW (3.4 HP) servo ball screw stroking system allows for increased flexibility and performance.
- 7 Heavy-duty welded base for durability.
- 8 Easy to remove pans for cleaning and longer filter life.

Standard safety features include interlocked stainless steel sliding front panel, side and rear panels, and front mounted light curtain.

Standard integral coolant system with two filters for long life.





THE SV-20 PUTS YOU IN COMPLETE CONTROL FOR INCREASED PRECISION, CONSISTENCY, PRODUCTIVITY AND QUALITY

- **Full bore profile display** – projects a real-time display of the bore cross section (see screen shots on next page) that simplifies removing taper from the bore ... allows user to dwell in the exact position as long as necessary where bore is visually smaller – a Sunnen innovation.
- **Size Lock** – allows for automatic shutoff with a preset stock removal amount.
- **Rough and finish cycles** - rough cycle removes stock fast and can be set to automatically switch to finish cycle for optimum bore geometry and for the desired crosshatch angle.
- **Standard programmable Auto Dwell for unattended operation** - the machine automatically dwells in the tightest part of the bore – top, middle or bottom.
- **Advanced control** – allows variable speed for a much wider range of control and consistent crosshatch pattern. Switch from rough to finish honing with one push of a button.
- **Automatic crosshatch calculator** – calculates stroke speed and spindle speed for a specific crosshatch.

Machine Options include:

1. T-slot base plate for custom fixturing
2. Heavy-duty Manual Rollover Cradle for engine blocks, pictured left (Both above options allow easy change over from cradle to T-slot)
3. Block Clamp Kit
4. Sump pump to allow connection to an external coolant system
5. Work area light kit
6. 208/230 VAC Transformer

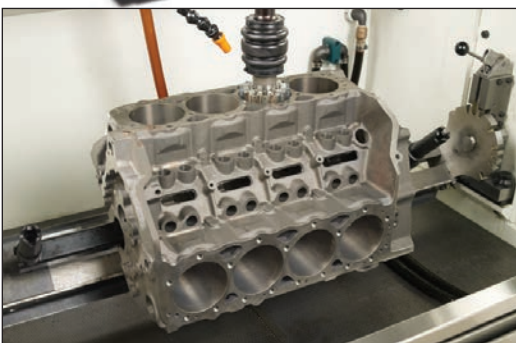



THE SV-20 FEATURES SUNNEN'S INNOVATIVE BORE PROFILE DISPLAY

The innovative, easy-to-read and easy-to-use bore profile display screens take the guess-work out of removing taper.

Sunnen, the leader in honing technology, was the first to offer the bore profile display which provides a real time graphical display of the bore cross section, allowing

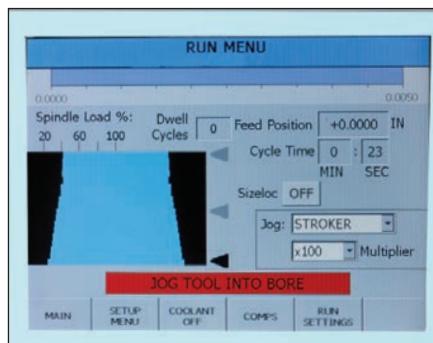

the operator to see where the bore is smaller and manually correct taper without guesswork.

SPECIFICATIONS:

SPINDLE SPEED:

15 - 600 RPM

SPINDLE POWER:

4.1 kW (5.5 hp)

STROKER:

2.5 kW servo (3.4 hp)

Variable speed: 100 SPM

Stroke Length: up to 680 mm (26.8 in)

CARRIAGE TRAVEL:

838 mm (33 in.) left/right travel available (X axis)

MAXIMUM WORKPIECE WEIGHT:

600 kg (1325 lbs)

WORKPIECE ENVELOPE:

1219 mm W x 760 mm D (48 in x 30 in)

MACHINE WEIGHT:

Dry Weight: 1329 kg (2930 lbs.)

Shipping Weight: 1823 kg. (4020 lbs)

HONING FLUID/FILTER SYSTEM:

Honing Oil Reservoir: 284-liter (75-gallon) capacity with two standard canister filters.

VOLTAGES AVAILABLE

Electrical System:

400 VAC 50 Hz 3 phase: 25.1 amps

460 VAC 60 Hz 3 Phase: 22 amps

(CE Compliant)

** DIAMETER RANGE, LENGTH RANGE AND WORKPIECE WEIGHT ARE CONTINGENT ON WORKPIECE AND APPLICATION.*

SV-20 WORK AREA AND DIMENSIONS

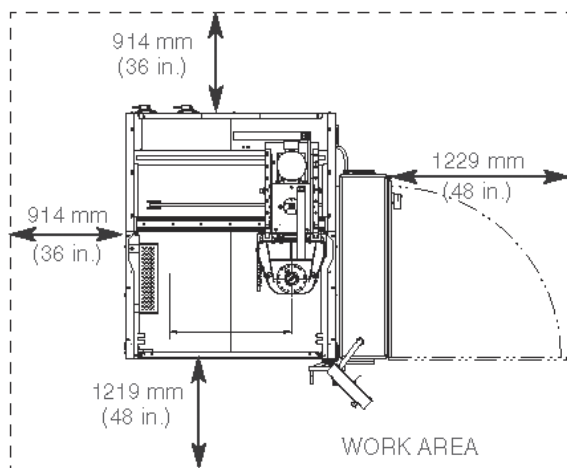

OVERALL MACHINE HEIGHT: 3315 MM (1305.5 IN)

OVERALL MACHINE WIDTH, SIDE: 2064 MM (81 IN)

OVERALL MACHINE WIDTH, FRONT: 1831 MM (72 IN)

SV-20 TOOLING, ABRASIVES AND LUBRICANTS

You get many tooling choices with the SV-20. It allows you to choose the exact tooling and abrasive to meet your specific production requirements and will use the same tooling you've come to depend on with the CK-21. Sunnen is the only full-line company that produces its own precision honing abrasives. And with the largest variety of diamond or Borazon® superabrasives and conventional vitrified abrasives, you are assured of most exact and consistent surface finish in the industry.



DH-SERIES DIAMOND HONING SYSTEM

Sunnen's Diamond Honing System features multi-point cutting action that spreads out force for faster, rounder bores and greatly improves productivity and performance. Three different tools cover the size range. An excellent choice for blind bores or ported cylinder heads.

BORE DIAMETER RANGE:
70 - 141 mm (2.75 - 5.5 in.)

SUNNEN CV-TYPE TOOLING

Industry standard CV-Type tools are the reason an SV-20 can do the same job as bigger machines costing two or three times as much. CV-Type tools cut fast. They're rugged, economical and easy to use. They have a large range, and the stones can be changed in seconds. Bores are finished faster and more accurately with minimum stock removal.

BORE DIAMETER RANGE:
51 - 203 mm (2-8 inches)

SUNNEN CK-TYPE TOOLING

Two abrasives and two die cast zinc guides provide an effective way to finish a large range of bore diameters. These tools use conventional abrasives and can be fitted with metal bond super abrasives, plus they're well suited for short production runs, engine rebuilding, and other precision honing operations.

BORE DIAMETER RANGE:
51-203 mm (2 - 8 inches)

GHSS/GHTS TOOLING

Sunnen's GHSS/GHTS multi-stone tools are designed for use with metal bond CBN and diamond abrasives for fast cutting action and reduced cycle times. The GHTS is a two-stage tool that performs both rough and fine honing operations (stone or brush) within the same honing tool – without changing stones – to reduce your bore sizing costs.

BORE DIAMETER RANGE:
GHSS: 37,59 - 140,71 mm
(1.480 - 5.540 inches)
GHTS: 62 - 140,7 mm
(2.440 - 5.540 inches)

P20/P28 MANDRELS

These mandrels incorporate multiple stones aligned end-to-end to allow for long bore honing, with the P28 accommodating blind bore honing as well. Both P20 and P28 mandrels have replaceable abrasives and guide shoes. Requires CV-1010 adapter.

BORE DIAMETER RANGE:
P20: 19 mm - 25,40 mm
(.75 in - 1.000 in)
P28: 25,15 mm - 152,40 mm
(0.990 in - 6.000 in)

MPS/ANR MODULAR TOOLING

The MPS and ANR Tooling System can be used to convert any "big work" honing machine into a state-of-the-art bore finishing system. Allows you to hone a wide variety of materials, sizes and bore conditions quickly and economically. MPS and ANR Tooling require use of an FL6X adapter.

BORE DIAMETER RANGE:
MPS: - 50 - 299 mm
(1.98 - 11.5 inches)
ANR: 64 - 533 mm
(2.5 - 21 in)

SUNNEN ABRASIVES & LUBRICANTS

From aluminum oxide to silicon carbide to diamond and CBN, Sunnen offers the industry's largest variety of mounted or un-mounted stick abrasives, bond types, grain sizes and stone configurations.

Before any stone is shipped, it is graded and qualified, maintaining the most exacting quality control standards in the industry to assure you of the most precise honing performance available.

Sunnen's premium honing oils and coolants provide extreme lubricity for higher honing pressure and harder abrasives, delivering faster, lower cost-per-part and ultimately more profitable cutting rates.



A LEGACY OF EXCELLENCE SINCE 1924.

WORLDWIDE

Our global manufacturing, distribution, and sales and service network allows us to deliver quality Sunnen solutions worldwide.

And our state-of-the-art Technical Services Centers allow our technical experts to develop innovative solutions to customer application challenges. The Centers also provide answers for customer questions and training for Sunnen representatives around the world.

SUNNEN PRODUCTS COMPANY
WORLD HEADQUARTERS
St. Louis, MO – USA
Phone 1.314.781.2100
Fax 1.314.781.2268
Toll Free 1.800.325.3670
Email sunnen@sunnen.com
www.sunnen.com



AUSTRIA - SUNNEN AUSTRIA GMBH **HOHENEMS**

Phone +43 5576 74194
Fax +43 5576 74196
Email sales@sunnen.eu
www.sunnen.at

BELGIUM - SUNNEN BENELUX BVBA **KONTICH**

Phone +32 38 80 2800
Fax +32 38 44 3901
Email info@sunnen.be
www.sunnen.be

BRAZIL - SUNNEN DO BRASIL LTDA. **SÃO PAULO**

Phone +55 11 4177-3824
Fax +55 11 4362-3083
Email sunnen@sunnen.com.br
www.sunnen.com.br

CHINA - SHANGHAI SUNNEN **MECHANICAL Co. LTD.** **SHANGHAI**

Phone +86 21 5813 3990
+86 21 5813 2299
Email shsunnen@sunnensh.com
www.sunnensh.com

CZECH REPUBLIC - SUNNEN S.R.O. **STRAKONICE**

Phone +420 383 376 317
Fax +420 383 376 316
Email sunnen@sunnen.cz
www.sunnen.cz

FRANCE - SUNNEN SAS **SACLAY**

Phone +33 169 30 00 00
Fax +33 169 30 11 11
Email info@sunnen.fr
www.sunnen.fr

INDIA - SUNNEN INDIA PVT. LTD. **MUMBAI**

Phone +91 223 913 6055
Fax +91 223 913 6056
Email sales@sunnen.in
www.sunnen.in

ITALY - SUNNEN ITALIA S.R.L. **ARESE**

Phone +39 02 383 4171
Fax +39 02 383 417 50
Email sunnen@sunnenitalia.com
www.sunnenitalia.com

POLAND - SUNNEN POLSKA Sp. z o.o. **WARSAWA**

Phone +48 22 814 34 29
Fax +48 22 814 34 28
Email sunnen@sunnen.pl
www.sunnen.pl

SUNNEN RUS LLC **MOSCOW – RUSSIA**

Phone +7 495 258 43 43
Fax +7 495 258 91 75
Email sunnen@sunnen-russia.ru
www.sunnen.ru

SWITZERLAND - SUNNEN AG **ENNETAACH**

Phone +41 71 649 33 33
Fax +41 71 649 33 34
Email sales@sunnen.eu
www.sunnen.eu

UK - SUNNEN PRODUCTS LTD. **HEMPSTEAD HERTS**

Phone +44 1442 39 39 39
Fax +44 1442 39 12 12
Email hemel@sunnen.co.uk
www.sunnen.co.uk

Sunnen reserves the right to change or revise specifications and product design in connection with any feature of our products contained herein. Such changes do not entitle the buyer to corresponding changes, improvements, additions, or replacements for equipment, supplies or accessories previously sold. Information contained herein is considered to be accurate based on available information at the time of printing. Should any discrepancy of information arise, Sunnen recommends that user verify the discrepancy with Sunnen before proceeding.